



Installation, Operating & Maintenance Sheet



SolConeX Receptacle & Plug 63 A

> 8579/41 & 8579/22



1 Contents

1	Contents	2
2	General Information	2
3	Application	3
4	Safety Instructions	3
5	Conformity to Standards	4
6	Technical Data	4
7	Transport and Storage	4
8	Receptacle Installation	4
9	Receptacle Wiring	5
10	Plug Wiring	5
11	Commissioning	7
12	Maintenance	7
13	Disposal	7

2 General Information

2.1 Manufacturer

R. STAHL Schaltgeräte GmbH
 Am Bahnhof 30
 74638 Waldenburg
 Germany
 Tel.: +49 7942 943-0
 Fax: +49 7942 943-4333
 Internet: www.stahl-ex.com

Manufacturer North American Contacts

USA

R. STAHL, INC.
 13259 N. Promenade Blvd.
 Stafford, TX 77477
 Tel.: 800 782-4357
 Fax: 281 313-9302
 Internet: www.rstahl.com

Canada

R. STAHL, LTD.
 7003 - 56 Avenue
 Edmonton, AB T6B 3L2
 Tel.: 877 416-4302
 Fax: 780 469-5525
 Internet: www.rstahl.com

2.2 Information regarding this Installation, Operation and Maintenance Sheet

ID-No.: 202145 / 8579620300
 Publication Code: 2013-09-03-IO00-III-en-02
 Subject to alterations.

2.3 Disclaimer

The nature of these instructions is only informative and does not cover all of the details, variations or combinations in which this equipment may be used, stored, delivered, installed, safely operated and maintained.

Since conditions of use of the product are outside of the care, custody and control of the manufacturer, the purchaser should determine the suitability of the product for his intended use, and assumes all risk and liability whatsoever in connection therewith.

Technical information and illustrations are not binding and subject to change without notice.

3 Application

The receptacle 8579/41 and plug 8579/22 are explosion protected equipment, certified for use in hazardous (classified) locations.

4 Safety Instructions

The receptacles and plugs must be used only for their intended purpose. Incorrect usage invalidates our warranty provision.

WARNING

Installation and maintenance of this product should only be performed by skilled and experienced personnel in accordance with the National Electrical Code (NFPA 70 - NEC) or the Canadian Electrical Code (CEC), respectively, and applicable local code regulations.

CAUTION:

- ▶ Disconnect power supply before installing or servicing these receptacles and/or plugs.
- ▶ Modifications to this product are not permitted.
- ▶ Operate only undamaged and clean devices with observations of the operating parameters in section 6.
- ▶ For a Class I Zone 1 conduit installation, conduit seals are required, refer to NFPA 70 (NEC) 505.16 (B) (1) or CEC C22.1. For any cable or other conduit installation, NO seals are required.
- ▶ Use only approved wiring methods for the location with the associated conduit/cable fittings.
- ▶ The receptacle is suitable for use on a circuit capable of delivering not more than 10,000 rms symmetrical amperes, 600 V maximum, when protected by properly sized Class J fuses, 150 amperes maximum. Supply wires shall be rated for + 75 °C.

5 Conformity to Standards

The 8579/41 Series of receptacles and the 8579/22 Series of plugs have multiple certifications printed on the nameplate.

6 Technical Data

Please refer to the technical data on the nameplates.

Explosion protection	
NEC	Class I, Zone 1&2, AEx d e IIC T6 Gb Class I, Div. 2, Groups ABCD Class II, Div. 1 & 2, Groups EFG Class III Ta = -30 °C (-22 °F) ... +40 °C (+104 °F)
CEC	Class I, Zone 1, Ex d e IIC T6 Gb Class I, Div. 2 per CEC J18-150 Class II, Div. 1, Groups G Ta = -30 °C (-22 °F) ... +40 °C (+104 °F)
IECEX	Ex d e IIC T6 (Ta = - 30 ... + 40 °C) Ex d e IIC T5 (Ta = - 30 ... + 55 °C)
ATEX	⊕ II 2 G Ex d e [ib] IIC T6, T5, T4 ⊕ II 2 D Ex tD A21 IP66 T60 °C...T105 °C

Certificates
NEC / CEC

IECEX
ATEX



FM File No. 0R6A2.AX
IECEX PTB 06.0020
PTB 01 ATEX 1150

7 Transport and Storage

- ▶ Transport and storage are only permitted in the original packing.

8 Receptacle Installation

8.1 Enclosure mounting

Securely mount the receptacle in a vertical position as illustrated, using three 5/16" (8 mm) screws and suitable washers. Mounting dimensions are marked on the back of the receptacle housing.

8.2 Conduit/Cable installation

For conduit installation, connect 1 1/2" NPT conduit to the hub and avoid misalignment. For cable installation, connect a listed cable fitting to the hub. Conduit/cable fitting should not be tightened more than 60 ft-lbs (81 Nm) of torque.

8.3 Auxiliary contact

When using the 6 A rated early break and late make auxiliary contact for an electrical interlock or other control signal, connect 12 AWG copper wire to terminals 13 and 14. Torque the terminal screws to 3.54 in-lbs (0.4 Nm).

8.4 Function label

Remove the plastic function label (taped inside the cover), mark as required, remove backing strip and apply to the recessed area above the switch. Close the cover and tighten the cover screws.

8.5 Receptacle HP Rating

3-Phase	Horsepower
600 V AC	60
480 V AC	40
250 V AC	20

9 Receptacle Wiring

- ▶ Open the terminal cover and connect + 75 °C or greater copper supply wires. The supply side of the terminal block accepts up to two wires which are between 6 through 2 AWG per terminal.
- ▶ Allow proper length for bending and cut the conductors to length.
- ▶ Strip the conductor insulation 1" (25 mm) from the end.
- ▶ Insert the conductors into the appropriate terminals which are marked to correspond with the markings on the plug.
- ▶ Torque all terminal screws to 54 in-lbs (6 Nm); including all unused terminals.

10 Plug Wiring

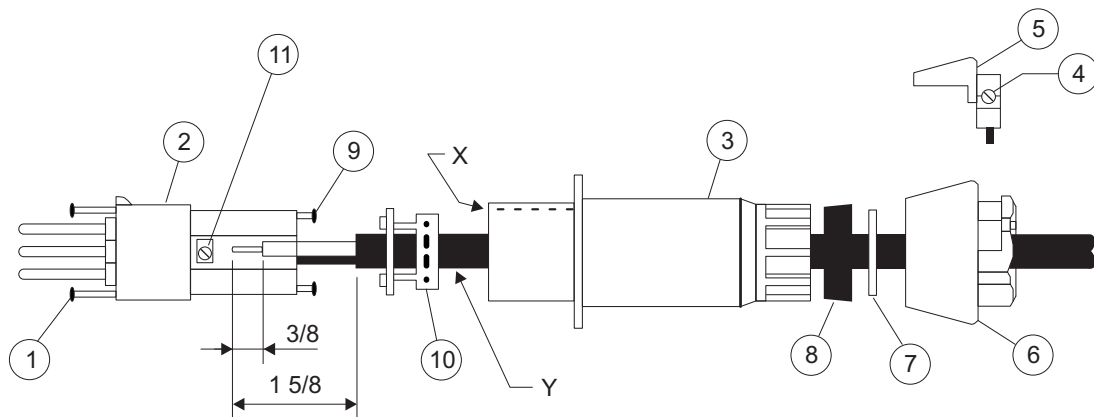

14967E00

Figure 1.

10.1 Cord type

Select a flexible cord with copper conductors of the appropriate insulation, ampacity and + 90 °C temperature rating. For installations in the U.S., refer to the National Electrical Code Articles 400-4, 400-5A, 400-5B, 501-11, 502-12 and 503-10. For installation in Canada, refer to CEC Sections 4 and 18.

	<p>Note: Maximum range for plug terminals is 10-6 AWG. Tighten terminal screws to 26.5 in-lbs (3 Nm) torque.</p>
---	--

10.2 Cord preparation

Cut the cord cleanly - Do not strip away cord jacket or conductor insulation at this time.

10.3 Opening the plug

Referring to Figure 1 above, loosen screws ① and pull the plug body ② out of the shell ③ . Loosen the screw ④ on the locking clamp ⑤ , insert the screwdriver in the locking clamp slot, lift the locking clamp out of the pressure ring ⑥ and unscrew the pressure ring.

10.4 Insert the cord

- ▶ Slide the pressure ring ⑥ and the washer ⑦ over the cord (Y).
- ▶ Install the cord grommet. The grommet ⑧ is an universal onion ring style which accommodates several cord diameters by removing (cutting out) the inner undersized diameters. The grommet should fit snugly on the cord. The grommet may require lubrication in order to slide over the cord. Use talcum powder or an equivalent material rated for use on electrical products. Slide the grommet over the cord with the cuts toward the shell ③ .

	<p>Note: If the grommet slides freely over the cord, there will be insufficient sealing for Class II and Class III Hazardous Locations.</p>
---	---

- ▶ Slide the shell ③ over the cord (Y).

10.5 Cord preparation

Dress the cord by removing the outer jacket and fillers for a length of 3-1/8" (80 mm) and strip the insulation off of the conductors 5/8" (17 mm) from the end.

10.6 Connection to terminals

Open the strain relief clamp screws ⑩ and flip the clamp to the side. Attach the leads to the appropriate terminals ⑪ . Terminal markings correspond to receptacle terminal markings.

⚠ WARNING

The Equipment Ground (green wire) is to be connected to the terminal marked with the Ground (Earth) symbol \perp .

10.7 Strain relief

Adjust the strain relief clamp ⑩ to slide over the cord (Y). If necessary, remove the clamp's plastic inserts to fit the plug body ② . Then tighten the strain relief clamp ⑩ .

10.8 Plug assembly

- ▶ Insert the plug body ② into the shell ③ . To align the plug body ② with the shell ③ , the keyway (X) on the inside of the shell must mate with the rib in the plug body.
- ▶ Tighten the screws ① .
- ▶ Slide the grommet ⑧ and the gland washer ⑦ forward until they shoulder against the shell ③ and tighten the pressure ring ⑥ until a good grommet compression is achieved.
- ▶ Reinstall the locking clamp ⑤ and tighten the screw ④ .

10.9 Optional dust cap

The optional dust cap (P/N 85 798 01 14 0) must be used for Class II Hazardous Locations.

⚠ WARNING

Observe the labels on the receptacle and plug with regard to the use of receptacle covers and plug dust caps.

11 Commissioning

Before commissioning into service

- ▶ Make sure that the device is not damaged.
- ▶ Make sure that the device is installed correctly.
- ▶ Remove any foreign objects from the device.
- ▶ Check the tightening torques.

12 Maintenance

These receptacles and plugs require no maintenance other than a periodic inspection for damage and proper operation. Any damaged equipment should be replaced promptly to ensure the electrical safety and explosion protection of the system.



Separate receptacles and plugs at regular intervals to prevent contact corrosion.

13 Disposal

The national and local waste disposal regulations have to be observed.